

# PRODUCT SHEET:

## RAMPTECH® DIESEL ENGINES



**WE'VE GOT THE POWER.  
REMANUFACTURED POWER.  
DIESELS FOR GSE.**

Like all RAMPTECH® products, Sage's RAMPTECH® Remanufactured GSE Engines are built to exacting specifications which not only meet but exceed the requirements for today's ramp applications. When you purchase a RAMPTECH® GSE Engine you can rest assured it's made to do the job like no other.

Sage offers RAMPTECH® GSE Engines in various configurations including:

- Basic Long Blocks (block and head only)
- Long Block Supremes tinwear and manifolds included
- Fully Dressed Drop-In engines that are ready to rumble

All Fully Dressed engines are Dyno tested prior to shipping, making them a true plug-and-play option.

FORD POWERSTROKE  
International T444E

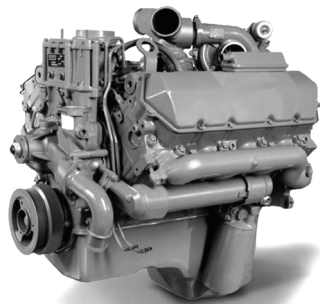

CUMMINS ISB02  
Complete Drop-In

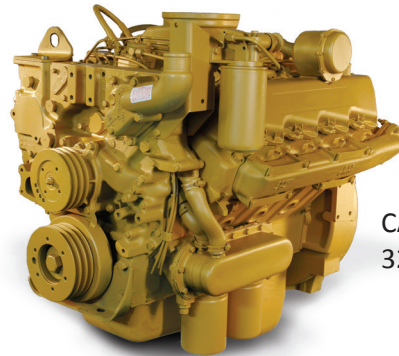
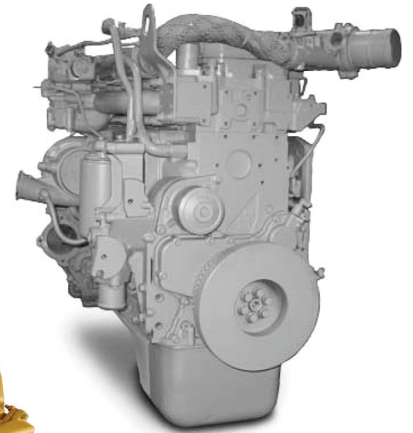

CATERPILLAR  
3208 Turbo

INTERNATIONAL  
DT-466 P Series

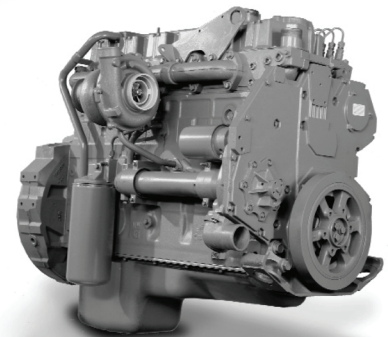

RAMPTECH® GSE Engines are built for most GSE configurations including: Air Start Units, Aircraft Tow Tractors, Baggage Tractors, Belt Loaders, Busses, Cabin Service Vehicles, Cargo Loaders, Catering Trucks, Fueling Vehicles, Ground Power Units, Heaters, Hydrant Trucks and Towbarless Tractors.

If it's on the ramp, RAMPTECH® has you covered.

# SAGE PARTS

Anticipating needs, meeting demands. Reducing costs.



Sage Parts  
30 Hub Drive, Melville, NY 11747  
+1.877.SAGE.877 | +1.631.501.1300 Tel  
+1.631.501.1619 Fax  
info@sageparts.com

[www.sageparts.com](http://www.sageparts.com)